

NaviTrack Scout

RIDGID®

EN	p. 3
DE	p. 17
FR	p. 33
NL	p. 49
IT	p. 65
ES	p. 81
PT	p. 97
SV	p.111
DA	p. 125
FI	p. 139
NO	p. 153
HR	p. 167
PL	p. 181
RO	p. 197
CZ	p. 212
HU	p. 226
EL	p. 241
RU	p. 257
SK	p. 273
SL	p. 288
SR	p. 302
TR	p. 316



RIDGE TOOL COMPANY



FIND IT



SEE IT



CLEAN IT

EN

NaviTrack Scout Operating Instructions

Original Instructions - English



GENERAL SAFETY INFORMATION

WARNING! Read and understand all instructions. Failure to follow all instructions listed below may result in electric shock, fire, and/or serious personal injury.

**READ THE ENCLOSED SAFETY INSTRUCTIONS.
SAVE THESE INSTRUCTIONS!**

The EC declaration of conformity (890-011-320.10) will accompany this manual as a separate booklet when required.

Battery Precautions

- **Use only the size and type of battery specified. Do not mix cell types (e.g. do not use alkaline with rechargeable).** Do not use partly discharged and fully charged cells together (e.g. do not mix old and new).
- **Recharge batteries with charging units specified by the battery manufacturer.** Using an improper charger can overheat and rupture the battery.
- Properly dispose of the batteries. Exposure to high temperatures can cause the battery to explode, so do not dispose of in a fire. Some countries have regulations concerning battery disposal. Please follow all applicable regulations.

1. Scout Use and Care

- **Use equipment only as directed.** Do not operate the Scout unless proper training has been completed and the owners manual read.
- **Do not immerse the antennas in water.** Store in a dry place. Such measures reduce the risk of electric shock and instrument damage.
- **Check for breakage of parts, and any other conditions that may affect the Scout's operation.** If damaged, have the instrument serviced before using. Many accidents are caused by poorly maintained tools.
- **Use only accessories that are recommended by the manufacturer for the Scout.** Accessories that may be suitable for one instrument may become hazardous when used on another.
- **Keep handles dry and clean; free from oil and grease. Allows for better control of the instrument.**
- **Protect against excessive heat.** The product should be situated away from heat sources such as radiators, heat registers, stoves or other products (including amplifiers) that produce heat.

1.1 Service

- **Diagnostic instrument service must be performed only by qualified repair personnel.** Service or maintenance performed by unqualified repair personnel could result in injury.
- **Provide proper cleaning.** Remove battery before cleaning. Do not use liquid cleaners or aerosol cleaners. Use a damp cloth for cleaning.

- **Conduct a safety check.** Upon completion of any service or repair of this product, ask the service technician to perform safety checks to determine that the product is in proper operating condition.
- **Damage to the product that requires service.** Remove the batteries and refer servicing to qualified service personnel under any of the following conditions:
 - If liquid has been spilled or objects have fallen into product.
 - If product does not operate normally by following the operating instructions.
 - If the product has been dropped or damaged in any way.
 - When the product exhibits a distinct change in performance.

In any correspondence, please give all the information shown on the nameplate of your tool including model number and serial number.

1.2 Important Notice

The Scout is a diagnostic tool that senses electromagnetic fields emitted by objects underground. It is meant to aid the user in locating these objects by recognizing characteristics of the field lines and displaying them on the screen. As electromagnetic field lines can be distorted and interfered with it is important to verify the location of underground objects before digging.

Several utilities may be underground in the same area.

Be sure to follow local guidelines.

Exposing the utility is the only way to verify its existence, location and depth. Ridge Tool Co., its affiliates and suppliers, will not be liable for any injury or any direct, indirect, incidental or consequential damages sustained or incurred by reason of the use of the Scout. Several utilities may be underground in the same area. Be sure to follow local guidelines.

2. Introduction to the Scout

The Scout™ sonde and line locator uses multi directional antennas and advanced processing to make pinpointing sondes and tracing buried utility lines fast, accurate and easy.

2.1 What are Its Unique Features?

Scout's advanced technology gives several unique features over conventional locators:

- Multi Directional Antenna System.
- Micro Map View.
- Indicate distinct signal characteristics.

2.2 What Does It Do?

The Scout is used above ground to sense electromagnetic fields emitted from underground or hidden lines (electrical conductors like metal wires and pipes) or sondes (actively transmitting beacons). When the fields are simple and undistorted, then the sensed fields are representative of the buried object. The Scout locates conductive objects emitting a field; it does not directly sense underground objects.

Electrical fields emitted by buried objects can be of two types; the first type is emitted by long conductors such as energized wires, inspection camera pushcables or pipes.

These objects produce a long cylindrical field and this is often referred to as "Line" tracing.

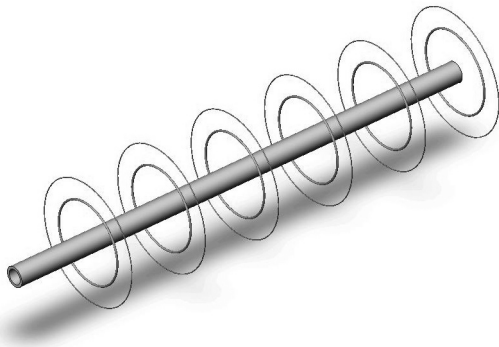

The field emitted by a charged line.

(Passive, AC Tracing is just a special case where the line is “energized” with electrical power.)

The second type, sondes (also called transmitters, beacons, or active duct probes), emit a differently shaped field and the Scout is programmed to measure and display this type of field. The more complex field shape of a sonde is called a dipole field, and is the same as that produced by a bar magnet and our planet Earth.

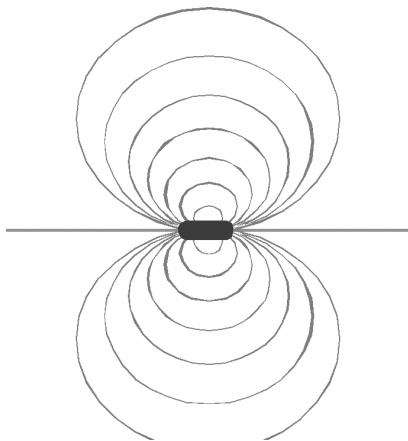

The dipole field emitted by a sonde.

Electromagnetic fields have three (3) important properties: frequency, strength and angle (direction). Unlike conventional locators, which can only measure strength in the direction of the individual antenna(s), the Scout measures both signal strength and field angles in three dimensions (3D). This enhanced capability makes the mapping display possible.

The experienced operator can use this additional information to speed the locating process and to help sort out complex locating situations. On the other hand, the occasional or novice user can easily locate using signal strength alone.

The Scout locating rule #1 is make the number big! –
Maximizing signal strength is the key, primary locating method.

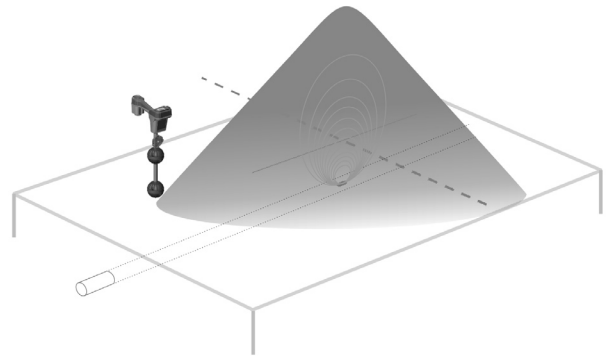

Example of how the Scout maximizes directly over the sonde.

Whether line tracing or locating a sonde, maximum signal strength occurs over the target. Depth is displayed when over the target.

2.3 What Is The Scout Multi Directional Advantage?

Viewing all of the signal with Multi directional antennas offers definite advantages:

1. Signal always gets stronger as user gets closer to the target.
2. Eliminates Nulls and “Ghost Peaks”. A conventional locator signal has a peak, then a null and then a smaller peak. This can confuse the operator, especially if they interpret a smaller peak as the target (known as “Ghost” or “False” peaks). The Scout sees just one peak to draw the user to the target.

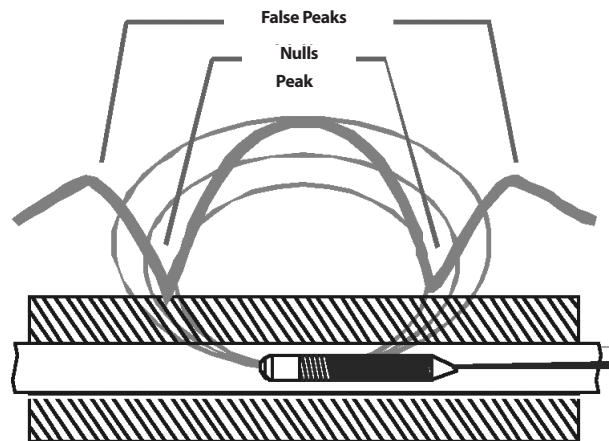

Sonde signal as “seen” by a conventional locator. Main peak in center and two false peaks outside the two nulls.

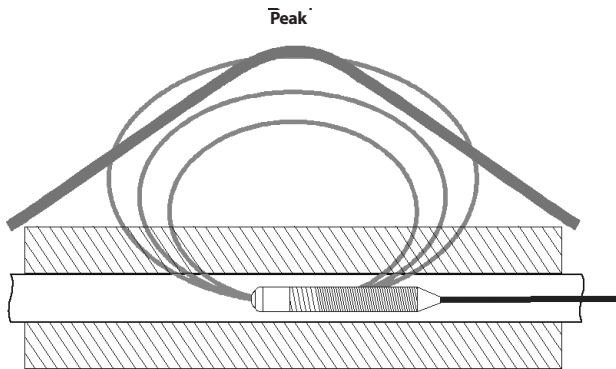

Sonde signal as “seen” by the Scout. Only one peak, no nulls.

3. How the unit is held does not affect signal strength.
The user can approach from any direction and does not need to know the lie of the pipe or wire.
4. Additional tools to identify and solve “difficult” locates include a graphical micro map and an angle indicator to help interpret signal characteristics.

2.4 What Is The Micro Map Advantage?

The map provides graphics that shows the signal’s characteristics. It is a bird’s eye view of the signal underground, shown graphically on the screen. It is used as a guide for tracing underground lines and can be used to better pinpoint sondes. It can also be used to provide more information for complex locates.

By moving the locator over the ground the Scout passes over the signal emitted by the underground objects. This allows the user to see on the screen, visualizations of the signal and then mark them. Conventional locators cannot map the underground signal as their antennas cannot see the complete shape of it.

3. Scout Components

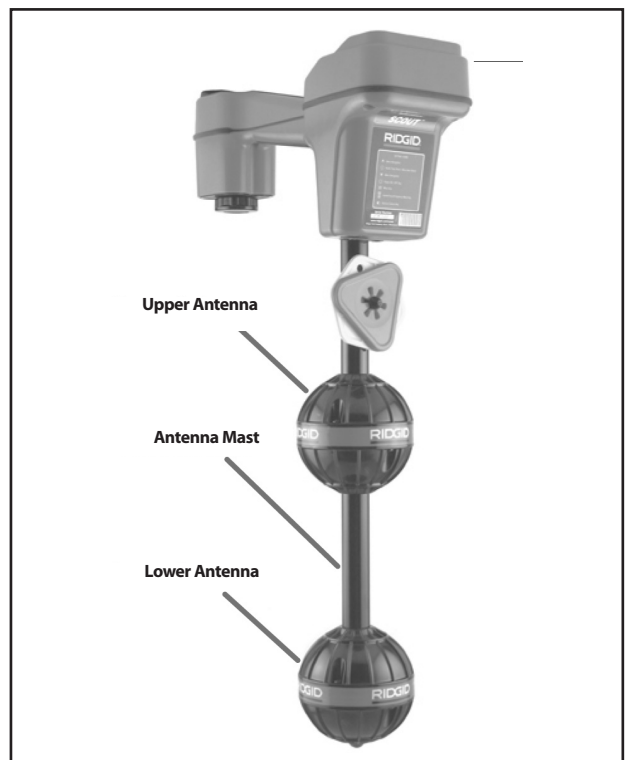
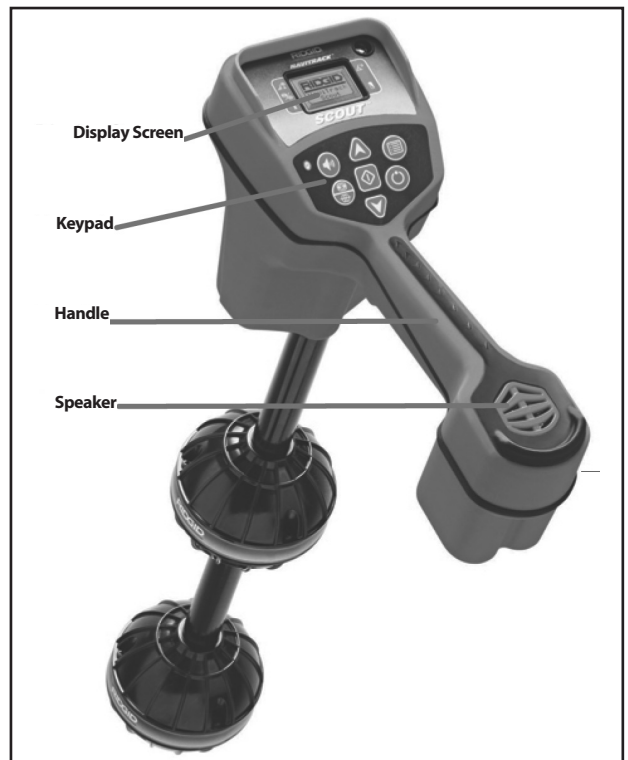



Display Screen



Keypad

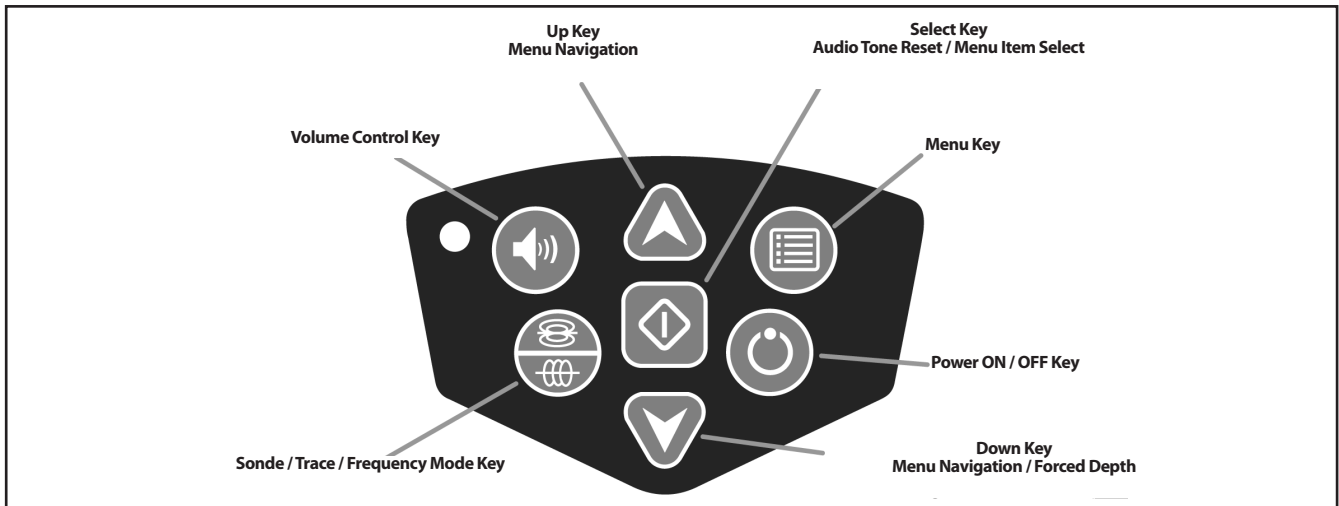

- Volume Control Key** – opens and closes the Sound Level menu.
- Sonde/Trace/Frequency Mode Key** – switches active frequencies and functions.
- Up Key** – scrolls up through menu choices.
- Select Key** – selects the highlighted choice when a menu is open.
- Down Key** – scrolls down through menu choices.
- Menu Key** – opens/closes the menu.
- Power ON/OFF Key** – turns the Scout on or off.

4. Getting started

4.1 Installing/Changing Batteries

To install batteries into the Scout turn the unit over to access the battery compartment. Turn the knob on the battery cover counter clockwise. Pull straight up on the knob to remove the door. Insert the batteries as shown on the inside decal and make sure they drop to full contact. Fit the door into the case and turn the knob clockwise while lightly pressing down to close. The battery cover can be installed in either orientation.

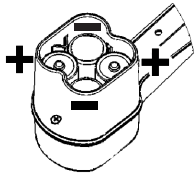

When the Scout is turned on it takes a few seconds to check the batteries. Until then the battery level will show as "empty".

⚠ WARNING

Do not allow debris to fall into battery compartment. Debris in the battery compartment may short the battery contacts, leading to rapid discharge of the batteries, which could result in electrolyte leakage or risk of fire.

4.2 Operation Times

Typical operation time for the Scout locator, when using alkaline cells, ranges from about 12 to 24 hours depending on factors such as sound volume, and how often the backlight is on. Other factors that affect the operation time will include chemistry of the battery (many of the new high performance batteries, such as the "Duracell® ULTRA" do last 10%-20% longer than conventional alkaline cells under high demand applications). Operation at low temperatures will also reduce battery life.

To preserve battery life the Scout will automatically shut down after 1 hour of no key presses. Simply turn the unit on to resume use.

4.3 Powering Up and Down

Turn the power on by depressing the Power key  on the keypad. The RIDGID® logo displays, the software version number will appear in the lower right corner.



Turn the unit off by depressing and releasing the Power key  on the keypad. Be aware there is a delay of a few seconds while turning on/off the unit.

4.4 Low Battery Warning

When the battery gets low, a battery icon will appear in the map area on the screen. This indicates that the batteries need to be changed and that the unit will soon shut down.

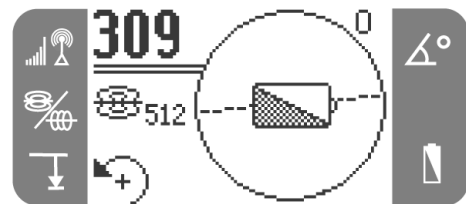

Just before complete shut down there will be a non-interruptable power down sequence.

In some cases the voltage on rechargeable batteries may drop so quickly that the unit will just shut down. The unit will turn off and restart. Just replace the batteries and turn the unit back on.

5. Set up

Once the Scout is up and running the next step is to set up the frequencies needed that match the equipment to be located. Each is activated for use by selecting them from a list in the menu.

1. Push the menu key, highlight the selection, then press the select key to activate:



2. Using the up and down arrows highlight a frequency to match the one used in the sonde or on the line transmitter, then press the select key to check the box. See the Menu Choices for reference. Hit the menu key to return to the main screen.

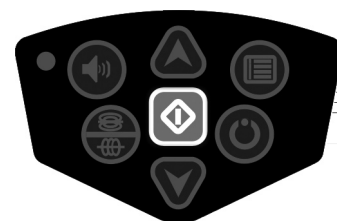



⚠ WARNING

Be sure that the frequency selected matches the desired use. 512 and 33 are available as a sonde AND a line trace frequency. Using a sonde frequency for line tracing or vice versa, can cause the Scout to display incorrect depth information.

- Now press the sonde/trace/frequency mode key to cycle through the activated frequencies and modes. Pay attention to the icons on the screen to see which mode the Scout is operating in.



- If the depth, auto backlight or LCD contrast needs to be adjusted then highlight the selection in the tools section of the menu and make changes using the select key.



5.1 Menu Choices

Sonde Mode Frequencies		512 Hz 640 Hz 874 Hz 33 Hz
Line Trace Mode Frequencies		50 Hz (Passive) 60 Hz (Passive) 512 Hz 8 kHz 33 kHz
Tools Menu		Feet/Meters Auto Back Light LCD Contrast

5.2 Sounds of the Scout

The sound is related to increasing or decreasing signal strength. It rises in pitch and volume when signal increases, or down when signal decreases. As the signal ramps up, it will step in pitch and volume on the way up only

to help push the operator to the maximum signal strength. If the signal strength drops, the sound returns to a base tremolo as if it saw no signal. The Scout has an automatic gain. When the gain moves up or down a step the sound will reset to the higher or lower intensity. Adjust the sound volume by pressing the Sound Key.



The volume will move with each press of the sound key or the up and down arrows can be used to adjust the volume as well. Press the select key to exit this screen.



NOTE Pressing the select key during normal operation will center the pitch to a medium level.

5.3 Overview - Understanding sondes and the Scout

Sondes (also called transmitters, beacons or active duct probes) emit an electro-magnetic field very similar to the magnetic field that emanates from the Earth.

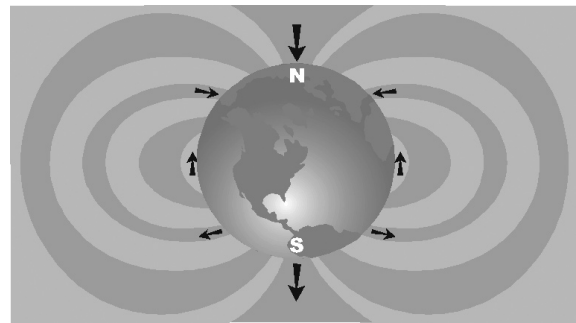

In fact, if the Earth were turned on its side, its magnetic field would look a lot like the field from a sonde.

As a locator, the Scout can measure the shape (angle) of the field lines from a sonde and identify distinct characteristics of these lines. Three important characteristics are the two **POLES** and the **EQUATOR**. At the Poles the angle of the signal is 90 degrees (vertical). At the Equator it is 0 (horizontal). Poles are distinct points in space, while the Equator wraps completely around the sonde. Since these distinct characteristics are constant, they can be used to accurately pinpoint the location of the sonde.

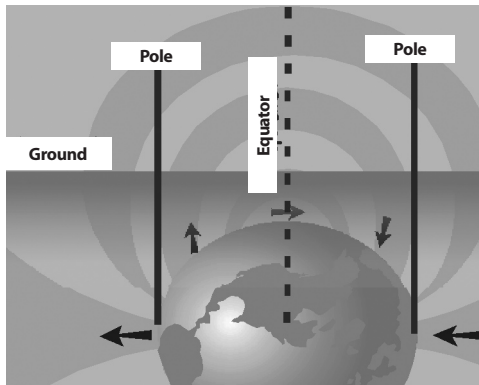

Poles usually occur where conventional locators would experience “nulls”, the dead spots that occur when the signal passes through their antennas vertically. The difference is that Scout can “see” the Poles (“nulls”) and show you where they are, **even when you’re not directly over them, and no matter how Scout’s antennas are aligned with the signal.**

This is one reason why locating with Scout is so much easier than with conventional locators.

The sonde is located at the point where the Equator passes directly between the two Poles.

5.4 Locating the sonde

The Scout can be used to locate the signal of a sonde (transmitter) in a pipe, so that its location can be identified above ground. Sondes can be placed at a problem point in the pipe using a camera push rod or cable. They can also be flushed down the pipe.

The following assumes that the sonde is in a horizontal pipe, the ground is approximately level and the Scout is held with the antenna mast vertical.

IMPORTANT Signal strength is the key factor in determining the sonde’s location. To ensure an accurate locate, you **MUST** take care to maximize the signal strength prior to marking an area for excavation.

5.4.1 When locating a sonde set up the locate in the following manner:

- **Before** putting the sonde in the line, use the Scout to make sure it’s operating and that Scout is receiving its signal.
- Once the sonde is in position and transmitting, activate the sonde and match the same frequency as the sonde on the Scout. Make sure it has a sonde mode icon

⚠ WARNING

Be sure that the frequency selected matches the desired use. 512 and 33 are available as a sonde AND a line trace frequency. Using a sonde frequency for line tracing or vice versa, can cause the Scout to display incorrect depth information.

- Go to the suspected sonde location. If the direction of the pipe is unknown, push the sonde a shorter distance into the line (~5m from the access, is a good starting point).

5.4.2 Next, use one of the following methods to locate the sonde:

Method 1 – Maximize Signal Strength

1. Hold the Scout so the mast is out away from your body. Sweep the mast in the suspected direction of the sonde while observing the signal strength and listening to the sound. The signal will be highest when the mast is pointing to the sonde.
2. Lower Scout to its normal operating position (mast vertical) and walk in the direction of the sonde. As you approach, the signal strength will increase and the audio tone will ramp and rise in pitch. Use the signal strength and the sound to **maximize the signal.**



3. Once the maximum has been found, place the Scout close to the ground over the peak and move in all directions to make sure that the signal drops off.

NOTE The highest signal counts, the equator line can be on a different position than the highest signal if the sonde is tilted (see section tilted sonde).

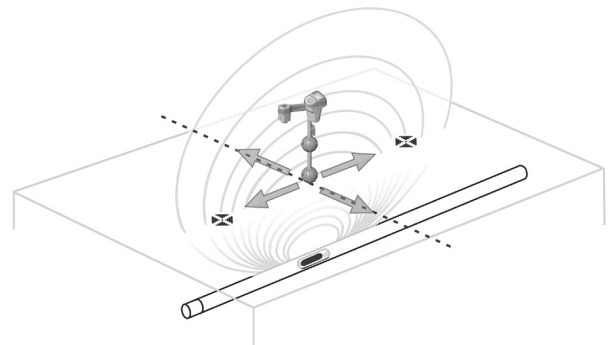

Method 2 – Follow the Equator – Then Maximize

1. Works best in unobstructed, open areas, **when the sonde is expected to be horizontal.** Sweep the mast and then walk in the direction of maximum signal strength as in Method 1.
2. When the Scout displays a steady Equator line centered on the screen, follow it towards increasing signal strength. When maximum signal strength is reached move the Scout along the Equator **and in all** directions to be sure that it is on the peak.

When the Sonde is tilted be sure the find the maximum signal as that is the place where the sonde will be.

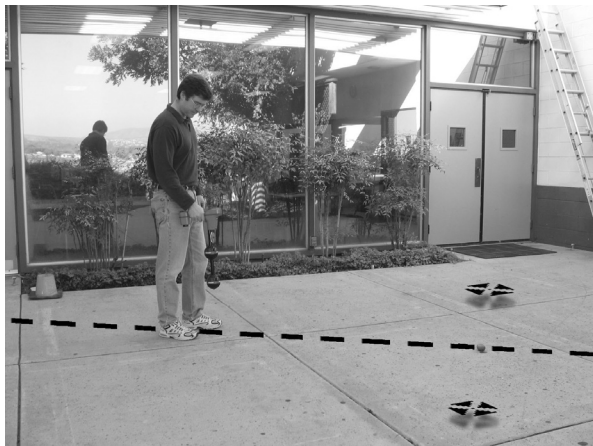

Verify the locate.

1. At the point of maximum signal strength, and with the mast vertical, move the Scout perpendicular to the Equator line on the screen. When the Pole icon appears move Scout until the Pole icon is centered on the crosshairs **with the lower antenna ball** on the ground. Place one of the triangle orange markers on the ground at this spot.



View when Scout is on the pole.

2. Move Scout back across the Equator line to the other pole. Center the crosshairs on the second Pole icon and mark its position as before.
3. Move back to the **maximum signal strength**. Mark this point on the ground with the **yellow hexagon marker chip**. Move the lower antenna ball slowly away from the yellow marker in all directions while observing the signal strength display. The signal strength should be highest directly over the sonde.
4. Look to see that all three markers are aligned and that the yellow hexagon marker is approximately halfway between the Pole markers.

If the yellow marker is not in the middle, see the section on tilted sondes.

IMPORTANT Being on the Equator does NOT mean you're over the sonde! Remember that signal strength is the key factor in locating the sonde. You must be at the point of highest signal strength. For best accuracy use the bubble level. The mast **MUST** be vertical when marking the Poles and Equator, or their locations will be incorrect!

5.5 Measuring Depth

The Scout measures depth by comparing the strength of the signal at the lower antenna to the upper antenna.

Depth is measured when the bottom antenna is touching the ground directly above the signal source.

1. To measure depth, place the locator on the ground, directly above the sonde or line. Make sure that the angle indicator reads 5 degrees or

less. Then slowly rotate the unit in the direction of the arrow shown on the **bottom left** of the screen until the depth appears.

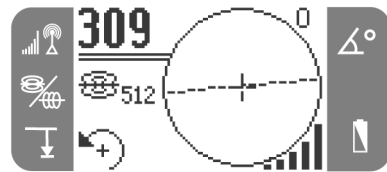

The bubble level is useful when measuring depth to make sure that the antenna mast is vertical.

In order to maximize signal and achieve a more accurate depth reading, the Scout needs to be rotated to align the antenna with the signal.

2. Depth will be shown in the lower left hand corner.



3. **Force Depth Feature** - If the angle indicator reads higher than 5 degrees then the Scout will not give a depth measurement. Press the down arrow key and hold it. This will force the depth if depth can be measured (see the following section on tilted sondes).

When checking the depth always take a measurement, then rotate the Scout 180 degrees (1/2 circle) and take another depth measurement. Be sure that the lower ball stays at the same position on the ground and the mast is vertical. If the depth readings are not within about 10% of each other then distortion is present and the depth reading should be questioned.

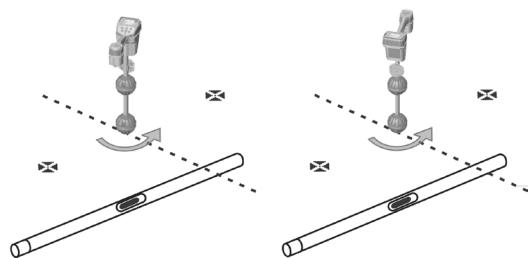

5.6 Operating Tips for Locating a sonde

- Use the sound when possible to help guide the Scout to the maximum signal strength.
- If the Equator is crossed, and the signal is not maximized, follow the Equator to the highest signal strength. Simply finding the Equator of the sonde (the dashed line on the screen) does NOT indicate that the sonde has been found. The point of maximum signal strength must also be found. If the sonde is steeply tilted, the Equator will NOT lie directly above the sonde and the distance from the sonde to each Pole will not be equal. If the sonde is tilted, maximize the signal.
- Always confirm the point of maximum signal strength. Verify what the map is showing, unless it is known for a fact that all the required conditions have been met. The map assumes the following conditions:
 1. The ground is level.
 2. The sonde is level.

3. The Scout Locator is above ground level.
4. The Scout Locator is held approximately vertical, antenna mast pointing straight down.

If these conditions are not met, pay close attention to maximizing signal strength. In general, if the above conditions are true and if the Scout is within about two “depths” of the signal source, the map will be useful and accurate. Be aware of this when using the map if the target or signal source is very shallow. The useful search area using the map alone can be small if the sonde is extremely shallow.

5.7 Tilted sondes

If the sonde is tilted, one Pole will move closer to the sonde and the other farther away so that the sonde location no longer lies midway between the two poles. The signal strength of the nearer Pole becomes much higher than that of the more distant Pole. In the extreme, as the sonde tilts to vertical, the one Pole moves to a point directly above the sonde and this Pole will

also correspond to the point of maximum signal strength. The other Pole will not be seen.

Therefore even if the sonde is vertical, as it could be if it fell into a break in the line or an underground tank, the sonde can still be located.

What is seen on the screen is a Pole of maximum signal strength when the sonde is vertical.

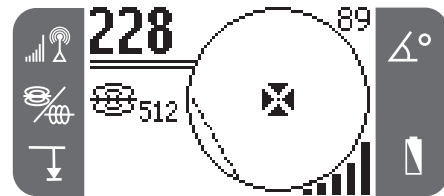

The multi directional antennas allow the depth to be measured even if the sonde is tilted. In this circumstance the force depth feature must be used to take a depth measurement (see Measuring Depth).

Micro map - Examples – Sonde Mode

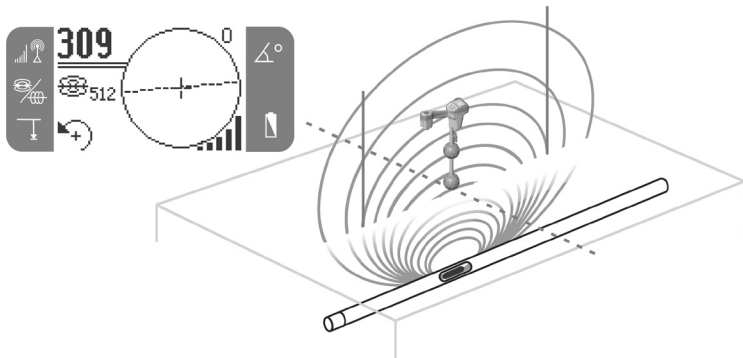

Scout on the Equator

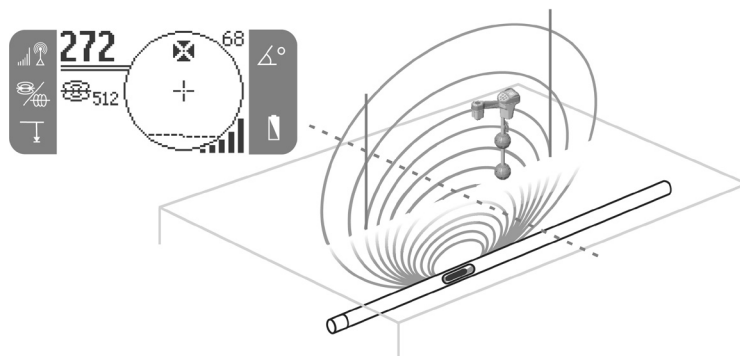

Scout leaves the Equator and approaches the Pole

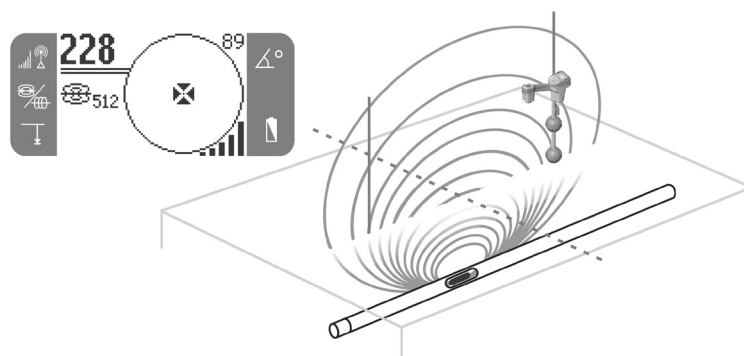

Scout on the Pole

6. Tracing a Line with Scout

The Scout can also be used to trace a pipe or line so that the ground above it can be marked. This identifies the line's location so that it can be avoided during a dig or exposed for repair or replacement. The Scout can locate energized lines with a variety of frequencies or it can be used passively to conduct a sweep to locate any long conductors carrying signals. Underground lines are energized with a line transmitter. This active signal is then traced using a receiver such as the Scout.

1. Attach the line transmitter to the line according to the manufacturer's instructions.

A "transmitter" is a generic name used for anything that generates a locatable signal. It is used to describe a sonde as well as the device that is used to energize a cable or pipe.

2. Match the frequency used on the transmitter with the same frequency on the Scout. Be sure it has a line trace icon ~. Push the main menu button to return to the locate screen.



3. When beginning the trace it is recommended that signal strength be observed first to see if it drops when the Scout is pulled away. Point the mast at the leads or the transmitter itself if using inductive mode. Over the line it should peak and drop off on either side. If the signal strength and lines on the screen DO NOT agree then the signal may be distorted.
4. When tracing, the way the pipe or cable is running will be shown on the screen with 2 solid lines. Keeping the lines on the center indicates that the Scout is tracing the line underground. If the line moves off to the left or right then move the Scout to get the line back on center. The signal emitted from a line is strongest directly over that line. If that is not the case then distortion is present.

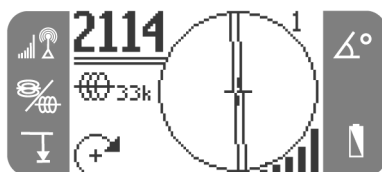

NOTE When using a line trace frequency there are two lines on the screen. When using a sonde frequency the Equator is a single line.

CAUTION Care should be taken to watch for signal interference that may give inaccurate readings. Depth readings should be taken as estimates and actual depths should be verified by exposing the line before digging.

5. When beginning the trace it is recommended that signal strength be observed first to see if it drops when the Scout is pulled away. Point the mast at the leads or the transmitter itself if using inductive mode. Over the line it should peak and drop off on either side. If the signal strength and lines on the screen DO NOT agree then the signal may be distorted.

6.1 Tracing a Passive AC Line

In passive mode the Scout senses alternating current, or AC fields. Buried power lines typically do not emit any traceable signal unless power is flowing in the wires. For example street lights that are turned off are hard to trace passively.

1. Select a Passive AC Trace Frequency with the passive line trace icon ~.
2. The Scout has two (2) passive AC tracing frequencies that are standard. They are 50 Hz and 60 Hz.

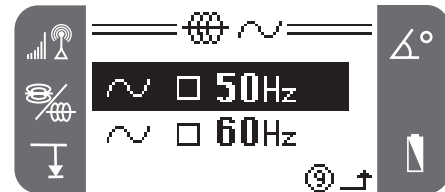

6.2 Operating Tips for Line Tracing

- **When the lines are not centered on the map, but signal strength is maximized, distortion is present!**
 - a. Try changing the frequency used to a lower one.
 - b. Move the ground stake position away from the line to be traced.
 - c. Make sure that the line is not commonly bonded to another utility.
- If the lines will not center or if they move across the screen inexplicably, then the Scout may not be receiving a clear signal.
 - a. Check the transmitter to be sure that it is operating and well grounded.
 - b. Test the circuit by pointing the lower antenna at either transmitter lead.
 - c. Check that the Scout and transmitter are operating on the same frequency.
 - d. Try different frequencies, starting with the lowest, until the line can be picked up dependably.
- Current flows best from the smallest lines to the largest (lowest resistance) lines. An example would be tracing a pipe from the house to the street.
- While tracing, the signal should maximize, and the depth minimize, at the same place where the lines centers on the display. If this is not the case, the utility may be turning or other coupled signals may be present.
- Higher frequencies bleed over more but may be needed to jump breaks in tracer wires or go over insulating couplers.
- When using the transmitter inductively be sure to begin the locate 10/15m away to avoid "air coupling". This is where the Scout will pick up the signal from the transmitter directly and not from the line to be traced.

If the lines will not center or if they move across the screen inexplicably, then the Scout may not be receiving a clear signal.

- a. The ground is level.
 - b. The line is level.
 - c. The Scout Locator is above ground level.
 - d. The Scout antenna mast is held approximately vertical.
- If these conditions are not met, pay close attention to maximizing signal strength. In general, if the Scout is within about two "depths" of the line, the map will be useful and accurate. Be aware of this when using the micro map if the target or line is very shallow. The useful search area in micro map can be small if the line is extremely shallow.

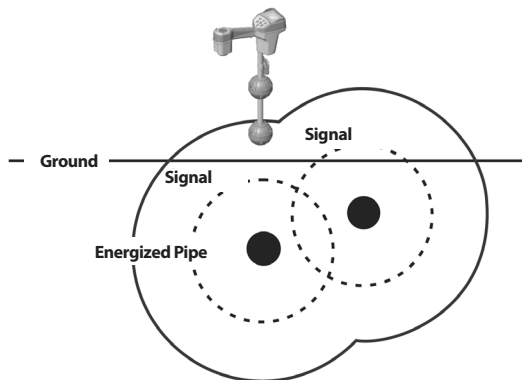

Micro map - Example – Line Trace

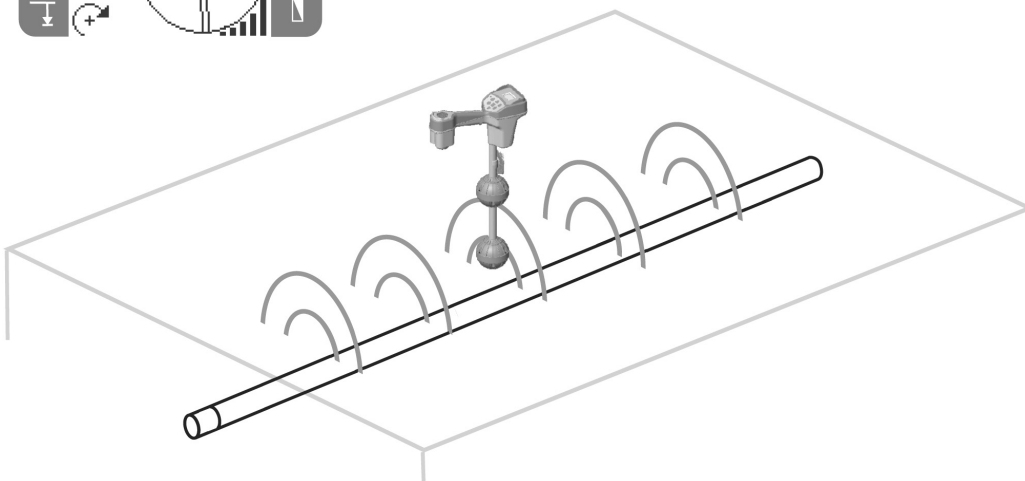
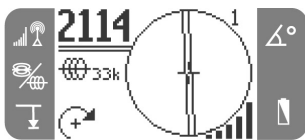

7. Tools Menu

7.1 Change of Depth Units

The Scout can change the units that it measures depth in to either Feet or Meters. To change these settings simply highlight the depth icon in the Tools Menu and then press the select key to toggle between feet or meters.



7.2 Auto Back Light

Low light levels are sensed by a light detector built into the upper left corner of the keypad. The backlight can be forced on by blocking the light to this sensor with a thumb.

The automatic LCD backlight is factory set to only turn on under fairly dark conditions. This is to conserve battery power. As the batteries near depletion, the backlight will appear dim. Near the end of battery life, the backlight operates at a very low level to conserve battery power.

To turn the backlight off, highlight the light bulb icon in the tools section of the menu and press the select key to toggle between Auto and OFF.



7.2.1 LCD Contrast

When this is highlighted and selected the LCD contrast can be adjusted with the up and down arrows.



8. Useful information

8.1 Signal Interference

8.1.1 Distorted Fields

Sometimes a single field may encounter metal or other ferrous material in the ground that may distort the field lines. It may be another utility, buried scrap or old unused lines that can shunt or shorten the field lines. In this case the Scout may display a weaker signal around the object and a stronger signal directly above it. The object may act as a lens that amplifies or weakens signal unpredictably.

8.1.2 Composite Fields

Composite fields are also possible. Where a single field meets another, the two, or more, may create a stronger signal. It is important for operators to understand this around "Ts" or right angles in the line, where composite fields are often encountered.

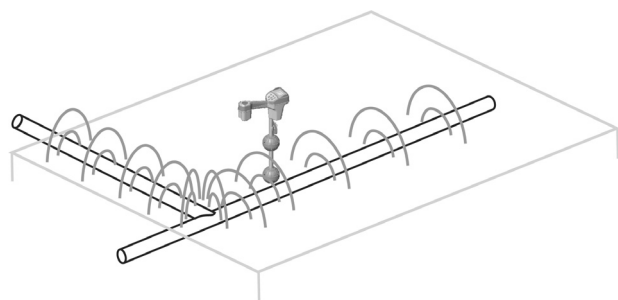

Composite field shown around a connection in the line.

8.1.3 Noise

Interfering signals (noise) are simply part of the locating challenge. Interference can either be at the same frequency being used, or it can be "out of band" at other frequencies. Some of the largest interfering signals are generated by power transmission equipment. Power transformers, large electric motors or generators and lines can be the source of very large noise signals. Areas that are particularly noisy should be avoided if possible.

If the angle display is unstable and not steady, and/or if the signal levels are not steady, this is a good indication of either no target signal present (sonde or energized line), or a high level of interfering noise.

8.2 Notes on Accuracy

Depth and Signal Strength measurements rely on a strong signal being received by the Scout. Remember that the Scout is used above ground to sense electromagnetic fields emitted from underground lines (electrical conductors like metal wires and pipes) or sondes (actively transmitting beacons). When the fields are simple and undistorted, then the sensed fields are representative of the buried object.

If those fields are distorted and there are multiple interacting fields, it will cause the Scout to locate inaccurately. Locating is not an exact science. It does require the operator to use judgement and look for all the information available beyond what the instrument readings may be. The Scout will give the user more information but it is up to the operator to interpret that information correctly. No locator manufacturer will claim that an operator should follow the information from their instrument exclusively. Conditions when locating accuracy must be questioned:

- **When other lines or utilities are present.** "Bleed over" may produce distorted fields and illuminate lines unintentionally. Use lower frequencies when possible and eliminate all connections between the two lines.

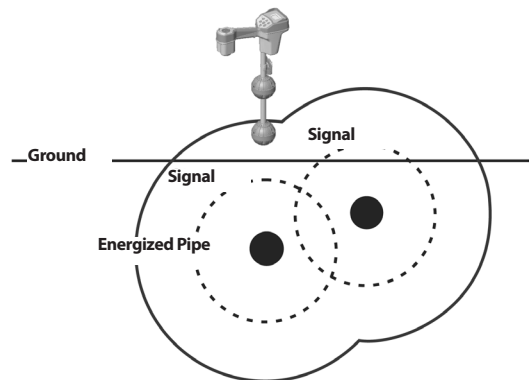

- **When using the transmitter inductively.** This gives the line a weak signal. Use a direct connection whenever possible.
- **When T's or splits are present in the line.** Can cause distortions in the signal.
- **When signal strength is low.** A strong signal is necessary for accurate locating.
- **When soil conditions vary.** Extremes in moisture, either too dry or overly saturated, may affect measurements. For example ground saturated with salty water, that might be found by the coasts, will shield the signal severely and be very difficult to locate in.

9. Transportation and Storage

Before transporting make sure that the unit is turned off to preserve battery power.

When transporting make sure that the unit is secure and does not bounce around or gets bumped by loose equipment.

The Scout should be stored in a cool dry place.

If storing the Scout for an extended period of time, the batteries should be removed.

10. Installing/Using Accessories

The Scout also comes with markers that can be used to mark Pole or sonde locations above ground. There are two (2) red markers to mark the poles and one (1) yellow marker to mark the sonde.

If further assistance is needed, please contact your dealer or a RIDGID representative.

11. Maintenance and Cleaning

⚠ WARNING

1. Keep the Scout clean with a damp cloth and some mild detergent. Do not immerse in water.
2. When cleaning, do not use scraping tools or abrasives as they may permanently scratch the display. NEVER USE SOLVENTS to clean any part of the system. Substances like acetone and other harsh chemicals can cause cracking of the case.

12. Locating Faulty Components

For troubleshooting suggestions, please refer to the Trouble Shooting Guide at the end of the manual. If necessary, contact Ridge Tool or your dealer for more information and help.

14. Trouble Shooting Guide

PROBLEM	PROBABLE FAULT LOCATION
Scout locks up during use.	Turn the unit off, then back on. Remove the batteries if the unit will not turn off.
While tracing, lines are "jumping" all over the screen in micro map.	This indicates that the Scout is not picking up the signal or there is interference.
	Make sure that the transmitter is well connected and grounded. Point the Scout at either lead to be sure that you have a complete circuit.
	Try a higher frequency.
	Try to determine the source of any noise and eliminate it.
While locating a sonde, lines are "jumping" all over the screen.	Check the batteries in the sonde to see if they are working.
	Verify signal by placing lower antenna close to sonde. Note – Sondes have difficulty emitting signals through cast iron and ductile iron lines.
Distance between sonde and either Pole is not equal.	Sonde may be tilted or there may be a cast iron to plastic transition.
Unit acts erratic, won't power down.	Batteries may be low. Replace with fresh batteries and turn on.
Display appears completely dark, or completely light when it is turned on.	Try powering the unit off and then back on.
	Adjust the LCD screen contrast.
There is no sound.	Adjust the sound level in the sound menu.
Scout will not pick up the signal.	Check if the correct mode and frequency is set.
Scout will not turn on.	Check orientation of batteries. Check if the batteries are charged. Check to see that the battery contacts are OK. Unit may have blown a fuse (factory service is required).

13. Service and Repair

⚠ WARNING

Tool should be taken to a RIDGID Independent Authorized Service Center.

15. Specifications

Weight w/ batteries.....	1,4 kg
Weight w/o batteries.....	1 kg
Dimensions	
Length.....	28,5 cm
Width.....	11,0 cm
Height.....	56,0 cm
Power Source	
4 C-size batteries, 1.5 V Alkaline (ANSI/NEDA 14 A, IEC LR14) or 1.2 V NiMH or NiCad rechargeable batteries	
Power Rating: 6 V, 550 mA	
Operating Environment	
Temperature.....	20°C to 50°C
Humidity	5% to 95% RH
Storage Temperature.....	-20°C to 60°C
Standard Frequencies	
Sonde.....	512 Hz, 640 Hz, 874 Hz, 33 kHz
Active Line Trace	512 Hz, 8 kHz, 33 kHz
Passive Line Trace	60 Hz, 50 Hz

Default Settings

The default settings for the locator are:
 Depth units = Meter and centimeter
 Volume = 1 (one setting above mute)
 Backlight = Auto

Standard Equipment

- Scout Locator
- Markers and Mast Holder
- 2 Operator's Manuals: US + Europe
- 4 C-cell batteries (Alkaline)
- Video PAL

Optional Equipment

- Additional Pole/sonde Markers
- NaviTrack Transmitter
- Inductive Clamp
- Battery Sonde
- Float

16. Icon Legend

DISPLAY ICONS

- Sonde Frequency
 - Active Trace Frequency
 - Passive (AC) Trace Frequency
 - Sound Level
 - Battery Level
 - Depth
 - Horizontal Angle Indicator
 - Signal Strength
 - Tools Menu
 - LCD Contrast
 - LCD Backlight
- #### KEYPAD ICONS
- Menu Navigation
 - Audio Tone Reset / Menu Item Select
 - Menu Navigation / Forced Depth (3 sec. press)
 - Power ON / OFF Key
 - Menu Key
 - Sonde / Trace / Frequency Mode Key
 - Volume Control Key

What is covered

RIDGID® tools are warranted to be free of defects in workmanship and material.

How long coverage lasts

This warranty lasts for the lifetime of the RIDGID® tool. Warranty coverage ends when the product becomes unusable for reasons other than defects in workmanship or material.

How you can get service

To obtain the benefit of this warranty, deliver via prepaid transportation the complete product to RIDGE TOOL COMPANY, Elyria, Ohio, or any authorized RIDGID® INDEPENDENT SERVICE CENTER. Pipe wrenches and other hand tools should be returned to the place of purchase.

What we will do to correct problems

Warranted products will be repaired or replaced, at RIDGE TOOL'S option, and returned at no charge; or, if after three attempts to repair or replace during the warranty period the product is still defective, you can elect to receive a full refund of your purchase price.

What is not covered

Failures due to misuse, abuse or normal wear and tear are not covered by this warranty. RIDGE TOOL shall not be responsible for any incidental or consequential damages.

How local law relates to the warranty

Some states do not allow the exclusion or limitation of incidental or consequential damages, so the above limitation or exclusion may not apply to you. This warranty gives you specific rights, and you may also have other rights, which vary, from state to state, province to province, or country to country.

No other express warranty applies

This FULL LIFETIME WARRANTY is the sole and exclusive warranty for RIDGID® products. No employee, agent, dealer, or other person is authorized to alter this warranty or make any other warranty on behalf of the RIDGE TOOL COMPANY.



Parts are available online at RIDGIDParts.com

**Ridge Tool Company**

400 Clark Street
Elyria, Ohio 44035-6001

We
Build
Reputations™

**Ce qui est couvert**

Les outils RIDGID® sont garantis contre tout défaut de fabrication ou de matériel.

Durée de la garantie

Cet outil RIDGID® est garanti pour toute la durée de vie du produit. La garantie prend fin lorsque le produit devient inutilisable pour des raisons autres que les défauts de fabrication ou de matériel.

Comment procéder pour bénéficier de la garantie ?

Pour bénéficier de cette garantie, renvoyez le produit complet en port payé à RIDGE TOOL COMPANY, Elyria, Ohio ou à un CENTRE DE SERVICE INDEPENDANT RIDGID® agréé. Les clés serre-tubes et autres outillages à main doivent être renvoyés à votre distributeur.

Les solutions que nous offrons

Les produits sous garantie sont réparés ou remplacés, au choix de RIDGE TOOL, et renvoyés gratuitement ; ou si après trois tentatives de réparation ou de remplacement pendant la période de garantie le produit est toujours défectueux, vous pouvez demander le remboursement complet de votre prix d'achat.

Ce qui n'est pas couvert

Les pannes dues à une mauvaise utilisation, à un emploi abusif ou à l'usure normale du produit ne sont pas couverts par la présente garantie. RIDGE TOOL ne se porte pas garant pour les dommages causés indirectement ou par accident.

Législation nationale affectant la garantie

Certains états n'autorisent pas l'exclusion ou la restriction touchant les dommages causés indirectement ou par accident. Il se peut que la restriction ou l'exclusion citée ci-dessus ne vous concerne pas. Cette garantie confère des droits spécifiques et d'autres droits peuvent s'appliquer, lesquels varient d'un état à l'autre, d'une province à l'autre ou d'un pays à l'autre.

Absence d'autres garanties expresses

Cette GARANTIE A VIE est la seule et unique s'appliquant aux produits RIDGID®. Aucun employé, agent ou distributeur, ni aucune autre personne n'est autorisé à la modifier ou à créer une autre garantie au nom de RIDGE TOOL COMPANY.

Cobertura de la garantía

La garantía RIDGID® cubre los defectos de mano de obra y material de sus herramientas.

Duración de larga cobertura

Esta garantía se extiende a toda la vida útil de las herramientas RIDGID®. La garantía finaliza en el momento en que el producto deja de ser utilizable por razones distintas a defectos de mano de obra o material.

Modo de obtención de servicio

Para beneficiarse de esta garantía, el usuario deberá enviar el producto en su totalidad con franqueo pagado a RIDGE TOOL COMPANY, Elyria, Ohio, o cualquier CENTRO DE SERVICIO AUTORIZADO INDEPENDIENTE RIDGID®. Las llaves de tuberías y demás herramientas manuales deben ser devueltas a su lugar de adquisición.

Solución de problemas

Los productos en garantía serán reparados o sustituidos por cuenta de RIDGE TOOL y devueltos sin cargo alguno. Si, después de tres reparaciones o sustituciones dentro del período de garantía, el producto siguiera defectuoso, el usuario podrá optar por la devolución del importe de la compra.

Aspectos no cubiertos en la garantía

Esta garantía no cubre los fallos debidos al mal uso o al desgaste y deterioro normales. RIDGE TOOL no se responsabiliza de los daños o perjuicios fortuitos o imprevistos.

Aplicación de las leyes y normativas locales a la garantía

Algunos países no permiten la exclusión o limitación de los daños o perjuicios fortuitos o imprevistos, por lo que las limitaciones o exclusiones aquí mencionadas podrían no ser de aplicación en su caso. Esta garantía le otorga derechos específicos, aparte de los que usted pueda tener y que pueden variar según el país, región o provincia.

Exclusividad de la garantía aplicable

Esta GARANTÍA TOTAL es la única y exclusiva garantía aplicable a los productos RIDGID®. Ningún empleado, agente, distribuidor o demás personas están autorizados a modificar esta garantía o aplicar ninguna otra en nombre de RIDGE TOOL COMPANY.

EMERSON. CONSIDER IT SOLVED.